

# Solid Subframe Bushings Kit Installation Instructions SPL SSB Z32

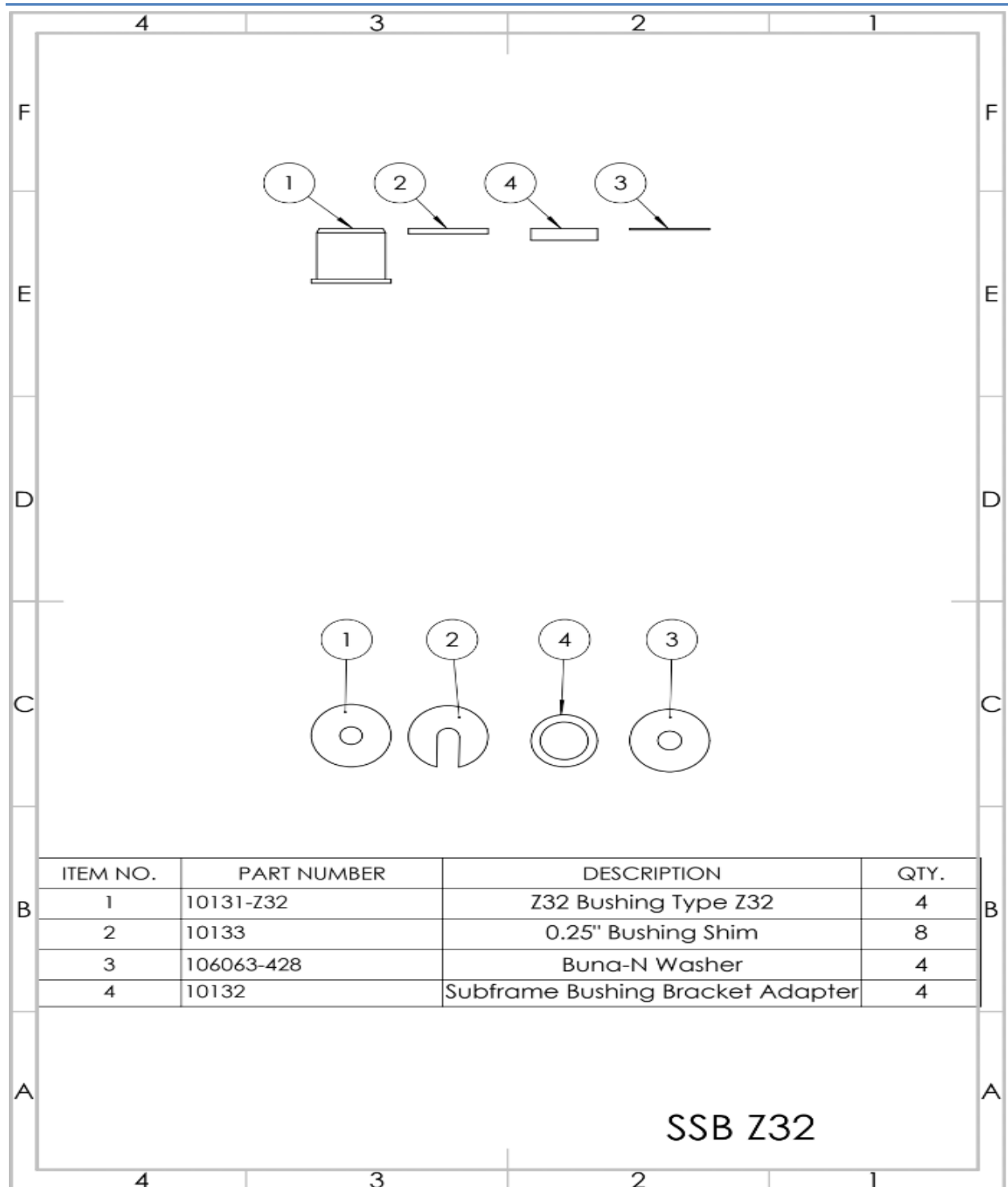

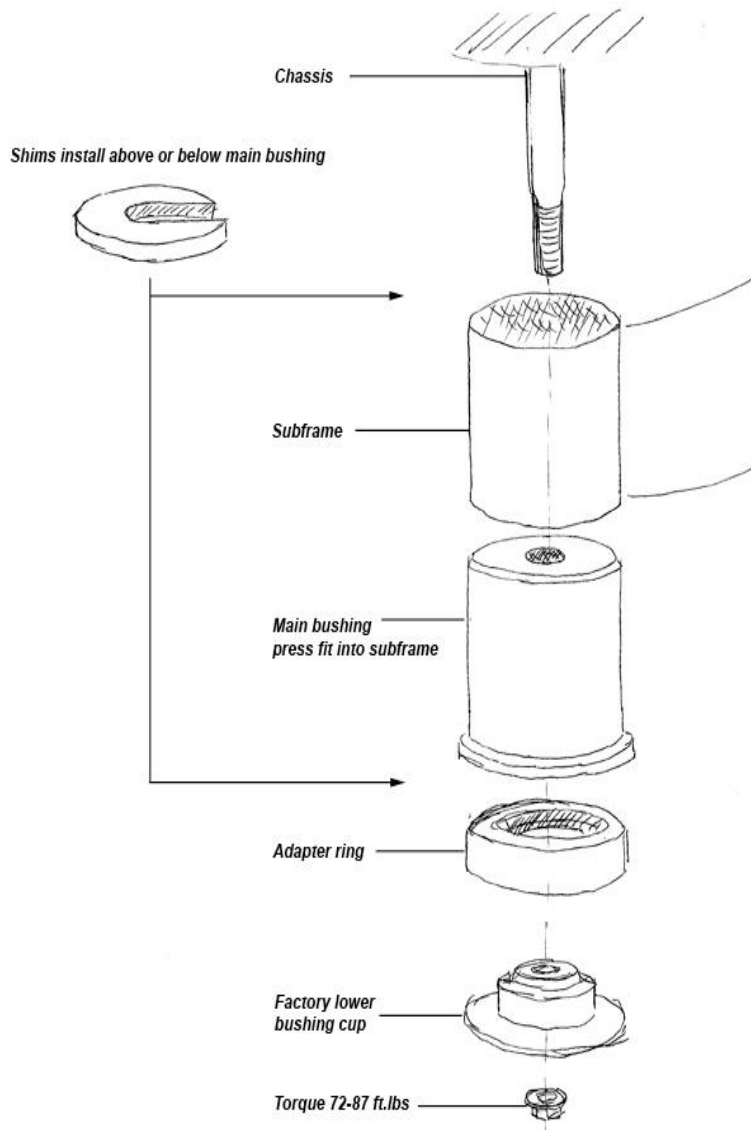

Place the aluminum bushings in the freezer the night before to ease installation. Remove subframe and OEM subframe bushings. The OEM subframe bushings can either be pressed out or cut out. The entire OEM bushing must be removed, including all the outer metal "shells" (race). When the OEM bushing is completely removed, there should just be 1 ring of steel left that is part of the subframe itself.

Press in the main bushing from the bottom of the subframe.

To place the subframe at the OEM location, place one bushing shim above and one bushing shim below at each corner of the subframe. You can raise and lower the subframe to change anti-squat and roll center by swapping the location of these shims to the top or bottom.

*Optional:* The supplied rubber isolators can be installed between the chassis and the subframe bushing to help dampen some noise.

The following 2 pages explain the effect of raising the subframe on roll center and anti-squat. For a car that is lowered, as a general rule, raising the subframe will improve the roll center but reduce traction. Feel free to experiment with different subframe positions to find the one that best suits your driving style!

**Note:** Raising the subframe will alter your rear alignment.

## Roll center adjustment and ride height adjustment by raising subframe

The following diagram depicts the subframe at the OEM location, with the stock ride height and roll center. Notice the gap between the subframe and the chassis, where the shims would sit.

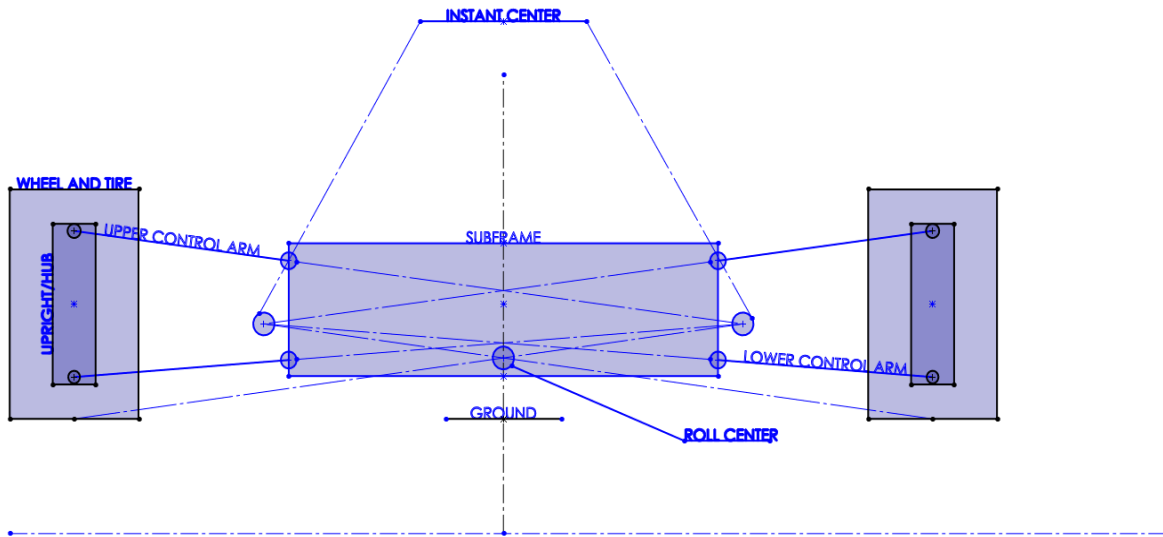

The following diagram shows the subframe raised closer towards the chassis (no more gap between subframe and chassis), and the ride height lowered the same amount. The roll center position is un-changed.

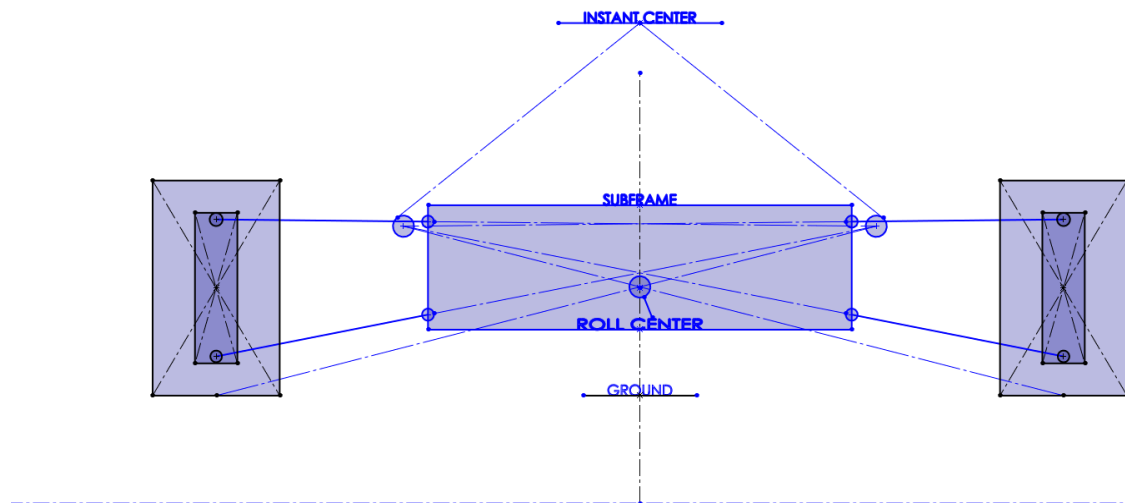

If we are to compare the 2 subframe positions with the car at the same ride height in both cases, raising the subframe will raise the roll center.

**Note:** Raising the subframe will not significantly change ride height because the ride height is determined by the shock/spring assembly, as it sits between the chassis and the knuckle.

## Raising subframe and effect on anti-squat

The ratio between the height from the ground to point "A", and the height from the ground to CG, is the amount of anti-squat. As a general rule, more anti-squat keeps the rear end from squatting under hard acceleration, and reduces traction.

The following diagram depicts the subframe at the OEM location, with the stock ride height and anti-squat. Notice the gap between the subframe and the chassis, where the shims would sit.

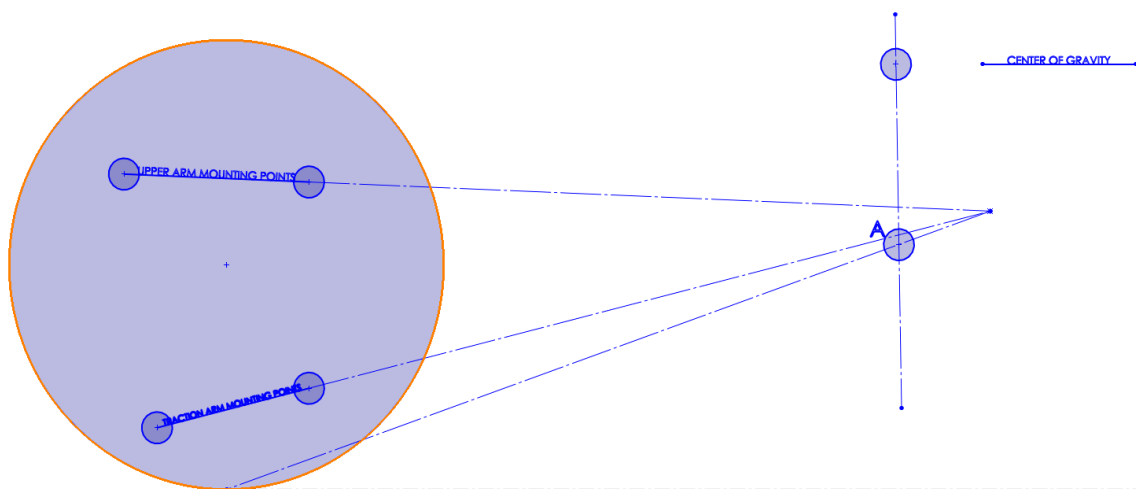

The following diagram shows what happens when you raise the subframe closer to the chassis. For this example, we are comparing what happens to the anti-squat when the ride height remains the same. When the subframe is raised, the rear "instant center" is raised as well, that moves point A up and increases anti-squat.

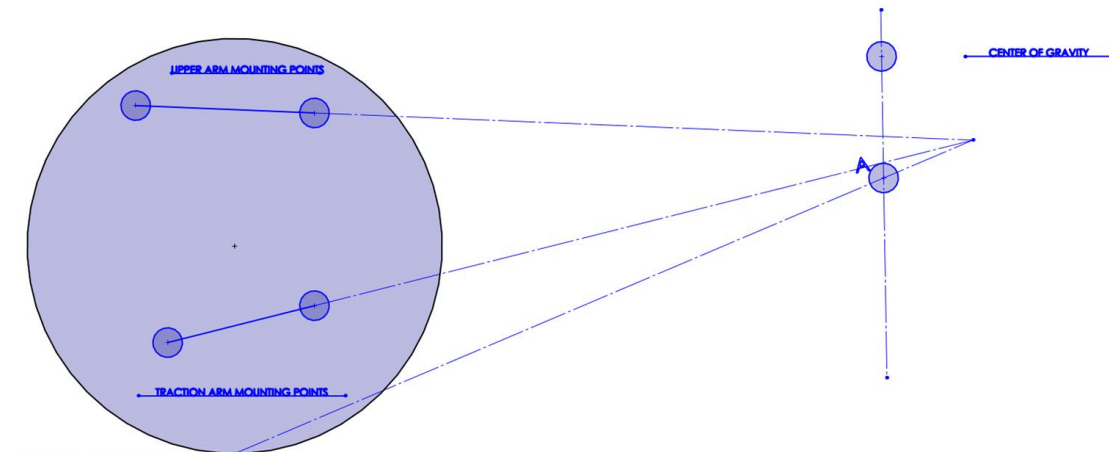

## **ONE-YEAR LIMITED WARRANTY AND DISCLAIMER**

All SPL brand products are intended for **Off Road Use Only** and carry a one year limited warranty. See below for details. All other branded products carry their respective manufacturer warranty.

SPL PRO suspension products warranted to be free of defects in material and workmanship for one (1) year from the date of purchase.

If a product fails to meet specifications, SPL PARTS INC will, at its election, repair, replace, or make appropriate adjustment, if SPL PARTS INC determines to its satisfaction that the product is defective in material or workmanship, i.e. contains a defect arising out of the manufacture of the product and not a defect caused by other circumstances, including, but not limited to accident, misuse, abuse, unforeseeable use, neglect, alteration, improper installation, improper adjustment, improper repair, or failure caused by other equipment or interaction with other equipment. SPL PARTS INC is not responsible for labor charges, removal charges, installation, or other incidental or consequential costs. In no event shall the liability of SPL PARTS INC exceed the purchase price of the product.

SPL PARTS INC makes no other warranties, either expressed or implied, including limitation warranties as to merchantability or fitness for a particular purpose. SPL PARTS INC shall not be liable for, and buyer assumes all risk of, any advice or failure to provide advice by SPL PARTS INC to buyer regarding the product or use and installation of product. SPL PARTS INC shall not be liable for any special, incidental or consequential damages.

If the purchaser of the product shall fail to pay when due any portion of the purchase price, or fail to meet any terms required under contract agreed on at time of purchase, all warranties and remedies granted may be terminated.

**Using any SPL arm as a tie/strap down point for a dyno session or transport will void the warranty.**